



Newland

SCANNING MADE SIMPLE



EM2037V4

OEM scan engine

integration guide

Disclaimer

© 2018 Fujian Newland Auto-ID Tech. Co., Ltd. All rights reserved.

Please read through the manual carefully before using the product and operate it according to the manual. It is advised that you should keep this manual for future reference.

Do not disassemble the device or remove the seal label from the device, doing so will void the product warranty provided by Fujian Newland Auto-ID Tech. Co., Ltd.

All pictures in this manual are for reference only and actual product may differ. Regarding to the product modification and update, Fujian Newland Auto-ID Tech. Co., Ltd. reserves the right to make changes to any software or hardware to improve reliability, function, or design at any time without notice. The information contained herein is subject to change without prior notice.

The products depicted in this manual may include software copyrighted by Fujian Newland Auto-ID Tech. Co., Ltd or third party. The user, corporation or individual, shall not duplicate, in whole or in part, distribute, modify, decompile, disassemble, decode, reverse engineer, rent, transfer or sublicense such software without prior written consent from the copyright holders.

This manual is copyrighted. No part of this publication may be reproduced, distributed or used in any form without written permission from Newland.

Fujian Newland Auto-ID Tech. Co., Ltd. reserves the right to make final interpretation of the statement above.

Revision History

Version	Description	Date
V1.0.0	Initial release.	September 6, 2018

Table of Contents

Revision History	- 3 -
About This Guide.....	1
Introduction.....	1
Chapter Description.....	1
Explanation of Symbols	1
Related Documents	2
Chapter 1 Getting Started	3
Introduction.....	3
Illumination	4
Aimer	4
Chapter 2 Installation	5
Introduction.....	5
General Requirements	5
ESD	5
Dust and Dirt.....	5
Ambient Environment.....	5
Thermal Considerations	6
External Optical Elements.....	6
Installation Orientation	6
Mounting.....	6
Mechanical Mounting Dimensions for the All-in-one Type (Unit: mm).....	7
Mechanical Mounting Dimensions for the Imager (Unit: mm)	8
Mechanical Mounting Dimensions for the Decoder Board (Unit: mm).....	10
Housing Design	11
Optics	11
Window Placement	11
Window Material and Color.....	12
Coatings and Scratch Resistance	13
Window Size	13
Skew, Roll and Pitch	16
Ambient Light.....	16
Eye Safety.....	16

Chapter 3 Electrical Specifications	17
Power Supply	17
Ripple Noise	17
DC Characteristics	17
Operating Voltage / Current	17
I/O Voltage	18
Timing Sequence.....	18
Power Up and Power Down Timing Sequence	18
Chapter 4 Interfaces	19
Interface Pinouts	19
12-pin FPC Connector	20
5-pin Box Connector	21
Connector/Cable Specifications (Unit: mm)	21
12-pin FPC Connector	21
5-pin Box Connector	22
12-pin FFC Cable.....	23
5-pin USB Female.....	24
External Circuit Design	25
Good Read LED Circuit	25
Beeper Circuit	25
Trigger Circuit.....	26
Chapter 5 Auxiliary Tools	27
EVK	27
EasySet.....	27

About This Guide

Introduction

The NLS-EM2037 OEM scan engines (hereinafter referred to as “the EM2037” or “the engine”) are armed with CMOS image capturer and the Newland patented **UIMG**[®], a computerized image recognition system-on-chip, featuring fast scanning and accurate decoding on barcodes on virtually any medium-paper, magnetic card, mobile phones and LCD displays. The EM2037 can be easily integrated into OEM equipment or systems, such as handheld, portable, or stationary barcode scanners. The EM2037 offers fully open image acquisition interface, raw data interface and I/O interface, which enable users to easily develop their own applications with Newland’s SDK.

※ Note: This guide provides general instructions for the installation of the engine into a customer's device. Fujian Newland Auto-ID Tech. Co., Ltd. recommends an opto-mechanical engineer should conduct an opto-mechanical analysis before integration.

Chapter Description

Chapter 1, Getting Started	Gives a general description of the EM2037.
Chapter 2, Installation	Describes how to install the engine, including installation information, housing design, optical, grounding, ESD, and environmental considerations.
Chapter 3, Electrical Specifications	Lists the electrical characteristics for the engine.
Chapter 4, Interfaces	Includes interface pinout, connector specifications and timing sequences.
Chapter 5, Auxiliary Tools	Introduces useful tools you can use to test and evaluate the EM2037 as well as conduct secondary development.

Explanation of Symbols

- This symbol indicates lists of required steps.
- ※ This symbol indicates something important to the readers. Failure to read the notice will not lead to harm to the reader, device or data.
- ⚠ This symbol indicates caution that, if ignored, may cause data or device damage or even personal injury.

Related Documents

- 12-pin FPC connector specification, CviLux Corporation, Model: CF20121V0R0-LF, <https://cvilux.en.taiwantrade.com/>
- 5-pin box connector specification, Xiamen Lianye Electronics Co., Ltd., Model: PH-5AW, <http://www.lyconnxm.com/>

Chapter 1 Getting Started

Introduction

The EM2037 is an area image engine for barcode reading. It includes an LED aiming system, and an LED illumination system.

LED Compliance Statement

The EM2037 complies with IEC 62471:2006 for LED safety.

The EM2037 contains:

- a CMOS image sensor and its lens
- a 2-LED based illumination system
- a 2-LED based aiming system

Figure 1-1 System Block Diagram

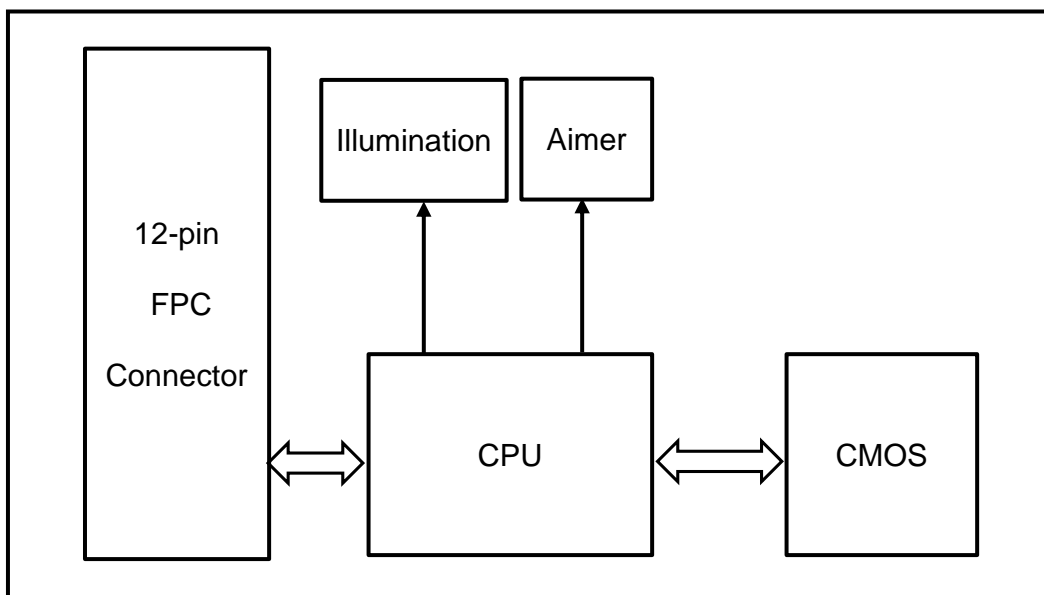

The 12-pin FPC connector on the engine can be connected to a host device with an FFC cable. For information about this cable, please see the “12-pin FFC Cable” section in Chapter 4.

Illumination

The EM2037 has two red LEDs (wavelength: 612nm-624nm) for supplementary lighting, making it possible to scan barcodes even in complete darkness. The illumination can be turned On or Off. The EM2037 uses red LEDs for illumination, so the engine shows better reading performance on barcodes printed in non-red colors. For applications involving red barcodes, it is advised to turn off the engine's illumination and use non-red supplementary lighting (such as green) instead. The user can conduct some tests to determine the proper wavelengths to be used.

Aimer

The EM2037 has a view finder that projects a bar-shaped aiming pattern to help the user to position the target barcode within the engine's field of view to increase scan efficiency. The aimer can be programmed On or Off. It is advisable to turn it on when scanning barcodes.

Chapter 2 Installation

Introduction

This chapter explains how to install the EM2037, including general requirements, housing design, and physical and optical information.

⚠ Caution: Do not touch the imaging lens when installing the engine. Be careful not to leave fingerprints on the lens.

⚠ Caution: Do not touch the illumination LED during handling. Improper handling may damage the LED.

General Requirements

ESD

ESD protection has been taken into account when designing the EM2037. However, due to limited board space, additional ESD protection, such as TVS protection, is not provided on the engine's I/O interface. It is advised to take corresponding protection measures when integrating the engine.

The engine is shipped in ESD safe packaging. Always exercise care when handling the engine outside its package. Be sure grounding wrist straps and properly grounded work areas are used.

Dust and Dirt

The EM2037 must be sufficiently enclosed to prevent dust particles from gathering on the lens and circuit board. Dust and other external contaminants will eventually degrade the engine's performance.

Ambient Environment

The following environmental requirements should be met to ensure good performance of the EM2037.

Table 2-1

Operating Temperature	-20°C to 60°C
Storage Temperature	-40°C to 70°C
Humidity	5% ~95% (non-condensing)

Thermal Considerations

Electronic components in the EM2037 will generate heat during the course of their operation. Operating the EM2037 in continuous mode for an extended period may cause temperatures to rise on CPU, CIS, LEDs, DC/DC, etc. Overheating can degrade image quality and affect scanning performance. Given that, the following precautions should be taken into consideration when integrating the EM2037.

- ✧ Avoid continuous use of the LED for prolonged periods.
- ✧ Reserve sufficient space for good air circulation in the design.
- ✧ Avoid wrapping the EM2037 with thermal insulation materials such as rubber.

External Optical Elements

Do not subject external optical components on the engine to any external force. Do not hold the engine by an external optical component, which may cause the mechanical joints that secure the components to crack or break due to excessive stress.

Installation Orientation

The **Figure 2-1** illustrates a front view of the EM2037 after correct installation.

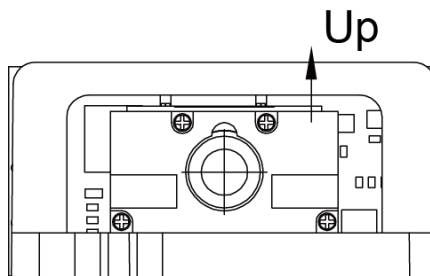

Figure 2-1

Mounting

The EM2037 provides all-in-one type and split type to cater for different mounting needs.

For the all-in-one type (the decoder board and the imager already assembled on an L-shaped bracket), the user can just mount the assembled unit on the target device.

For the split type, the user can mount the decoder board and the imager separately and connect them with an FFC cable.

The illustrations below show the mechanical mounting dimensions for the EM2037. The structural design should leave some space between components and reserve sufficient room for the installation of the FFC cable.

Mechanical Mounting Dimensions for the All-in-one Type (Unit: mm)

Front View

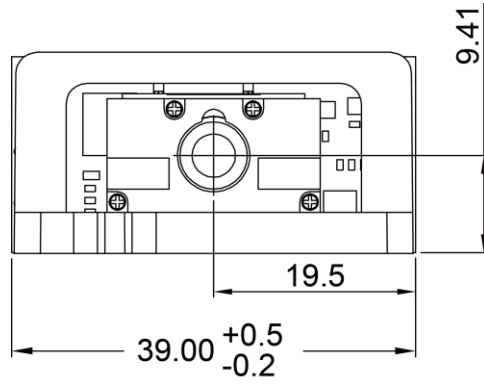

Figure 2-2

Bottom View

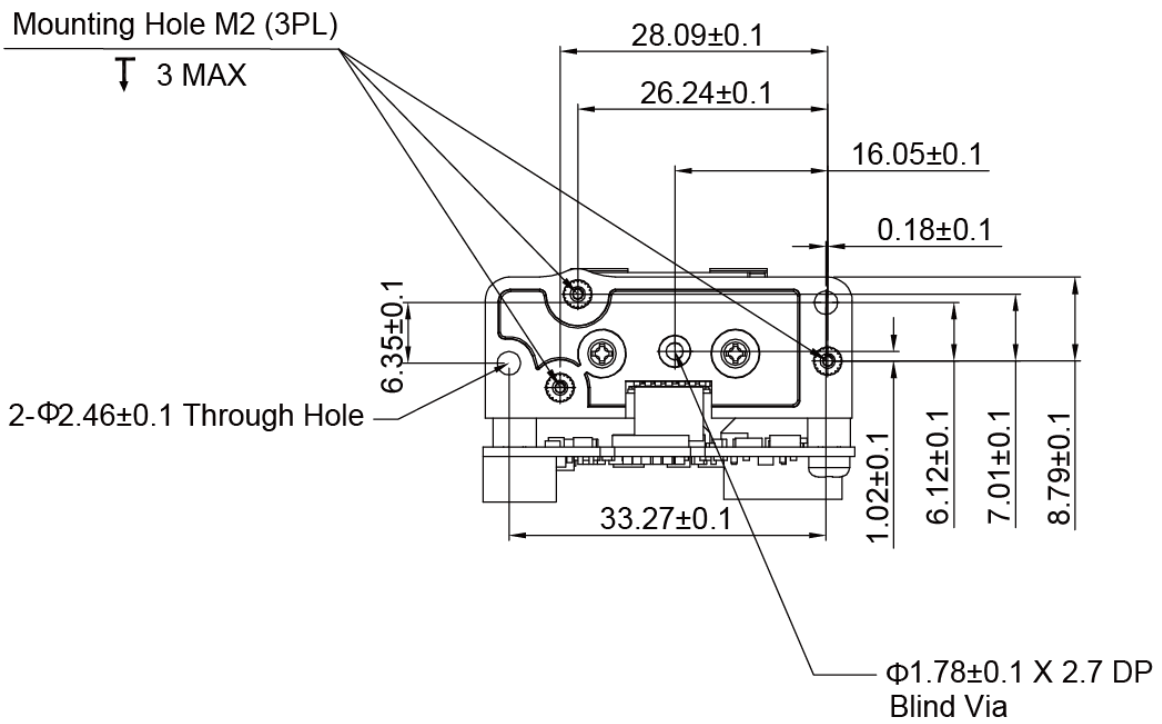

Figure 2-3

Side View

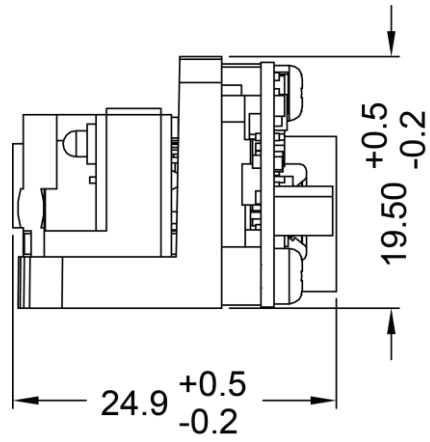

Figure 2-4

Mechanical Mounting Dimensions for the Imager (Unit: mm)

Front View

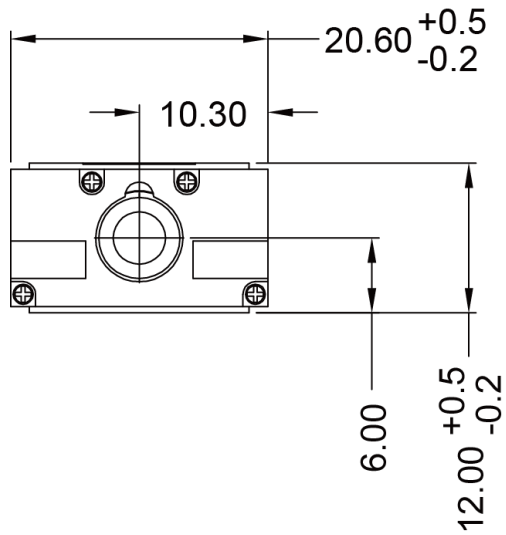

Figure 2-5

Top View

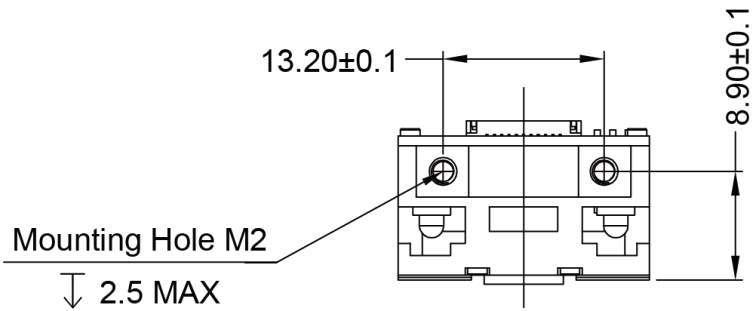

Figure 2-6

Bottom View

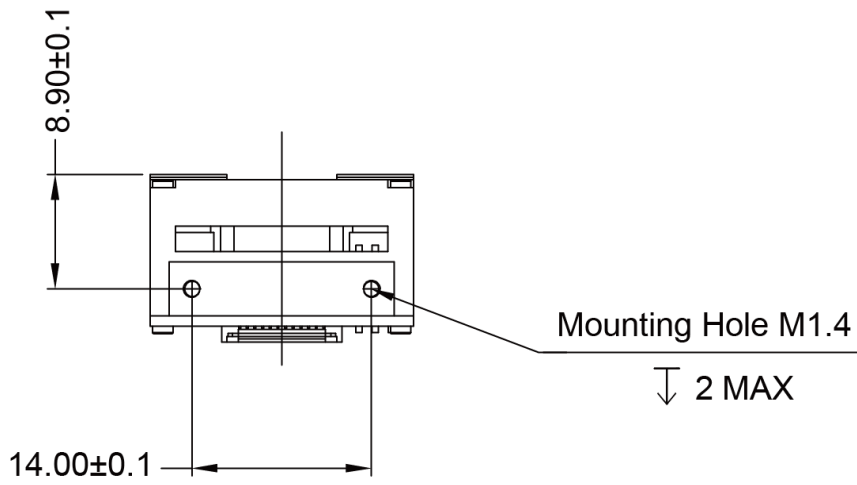

Figure 2-7

Side View

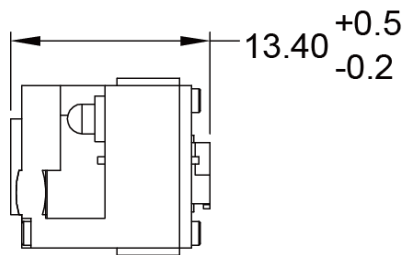

Figure 2-8

Mechanical Mounting Dimensions for the Decoder Board (Unit: mm)

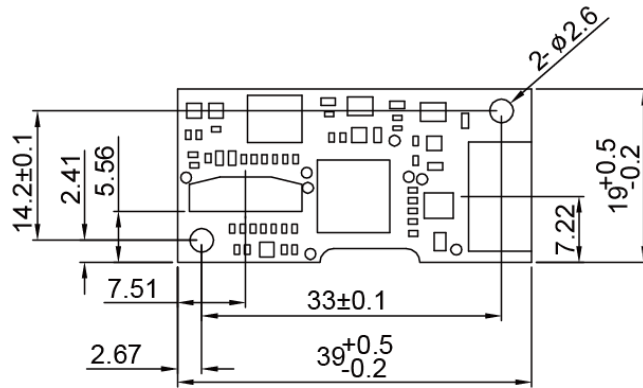

Figure 2-9

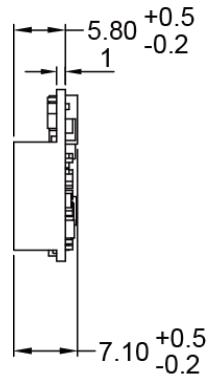

Figure 2-10 (With 5-pin box connector)

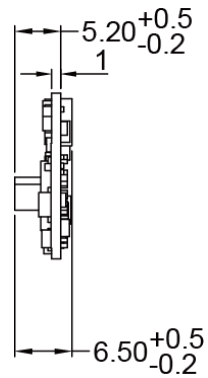

Figure 2-11 (Without 5-pin box connector)

Housing Design

※ Note: Conduct an optical analysis for the housing design to ensure optimal scanning and imaging performance.

Housing design should make sure that internal reflections from the aiming and illumination system are not directed back to the engine. The reflections from the housing or window can cause problems. For particular window tilt angles, the unwanted reflections can bounce off the top or bottom and reach the engine. Avoid any highly reflective objects around the engine that can cause bright spots to appear in the captured image. It is recommended to use baffles or matte-finished dark internal housing colors.

Optics

The EM2037 uses a sophisticated optical system. An improperly designed internal housing or improper selection of window material can degrade the engine's performance.

Window Placement

The window should be positioned properly to let the illumination and aiming beams pass through as much as possible and no reflections back into the engine (reflections can degrade the reading performance of the engine).

There are two window placement options.

- **Parallel window** – Primary option for imager engines. The following window distance requirements should be satisfied: The maximum distance is measured from the front of the engine housing to the furthest surface of the window. In order to reach better reading performance, the distance from the front of the engine housing to the nearest surface of the window should not exceed **a** ($a=1\text{mm}$) and the distance from the front of the engine housing to the furthest surface of the window should not exceed **a+d** ($a=1\text{mm}$, $d=2\text{mm}$), as shown in **Figure 2-12**.
- **Tilted window** - This option is for laser/imager engines. For the tilted window distance requirements, please see **Table 2-2**.

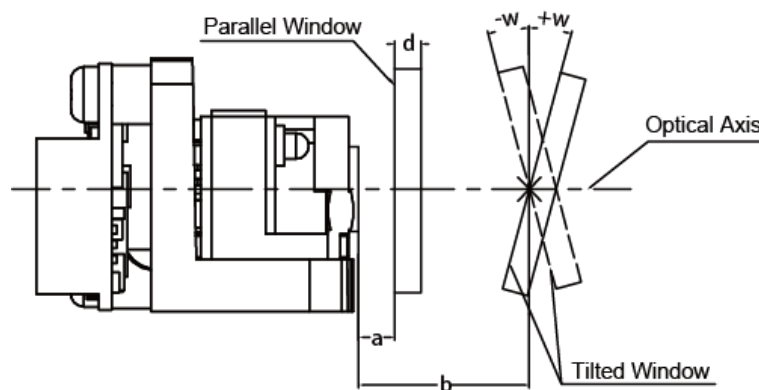

Figure 2-12

Table 2-2

Minimum Angle (Tilted Window)	Distance from the front of the engine housing (b)			
	5mm	10mm	15mm	20mm
Uncoated, minimum window positive tilt (+w)	25°	20°	18°	16°
Uncoated, minimum window negative tilt (-w)				
Anti-reflection coated, single side, minimum window positive tilt (+w)	22°	18°	16°	16°
Anti-reflection coated, single side, minimum window negative tilt (-w)				
Anti-reflection coated, double sides, minimum window positive tilt (+w)	20°	17°	15°	15°
Anti-reflection coated, double sides, minimum window negative tilt (-w)				

Window Material and Color

Window material must be clear. Use only cell-cast plastics or optical glass. PMMA, ADC and chemically tempered glass are recommended. Window material selected for the engine should meet or exceed the specifications specified in **Table 2-3**.

- **PMMA (Cell-cast acrylic):** When fabricated by cell-casting, has very good optical quality and low initial cost, but surface must be protected from the environment due to its susceptibility to attack by chemicals, mechanical stresses, and UV light. Reasonably good impact resistance. This material can be laser-cut into odd shapes and ultrasonically welded.
- **ADC (CR-39):** A thermal-setting plastic produced by the cell-casting process. Excellent chemical and environmental resistance. Quite good surface hardness, and therefore does not have to be hard-coated. Reasonably good impact resistance. This material cannot be ultrasonically welded.
- **Chemically tempered glass:** Glass is a hard material which provides excellent scratch and abrasion resistance. But unannealed glass is brittle. Increased flexibility strength with minimal optical distortion requires chemical tempering. Glass is hard to be cut into odd shapes and cannot be ultrasonically welded.

Table 2-3

Specification	Description
Spectral Transmittance	≥90%
Thickness	0.8-2.0mm
Wavefront Distortion	PV maximum: 0.2λ RMS maximum: 0.04λ
Clear Aperture	1.0mm to edges
Surface Quality	60-20 scratch/dig

Pay extra attention to the wavefront distortion when using plastic materials. Plastic materials are not recommended for tilted windows; colored windows are not recommended if the engine is used to scan barcodes on moving objects.

Coatings and Scratch Resistance

Scratch on the window can greatly reduce the performance of the EM2037. It is suggested to use abrasion resistant window material or coating.

The following introduces two commonly-used types of coatings:

- **Anti-reflection coatings:** Anti-reflection (AR) coatings can be applied to window surfaces to reduce reflected light from the window back into the engine. But they are expensive and have poor abrasion/scratch resistance.
- **Polysiloxane coatings:** Polysiloxane coatings can be applied to plastic surfaces to increase the surfaces' abrasion and scratch resistance.

Both tempered glass and plastic windows can be AR coated. However, it is easier and more cost-effective to put an AR coating on the glass than on the plastic.

The AR coating specifications below should be met when using an AR coated window.

Single side AR coating: 92% minimum transmittance within spectrum range from 420 nm to 730 nm.

Double side AR coating: 97% minimum transmittance within spectrum range from 420 nm to 730 nm.

Window Size

The window must not block the field of view and should be sized to accommodate the aiming and illumination envelopes shown below.

• SR version

Horizontal:

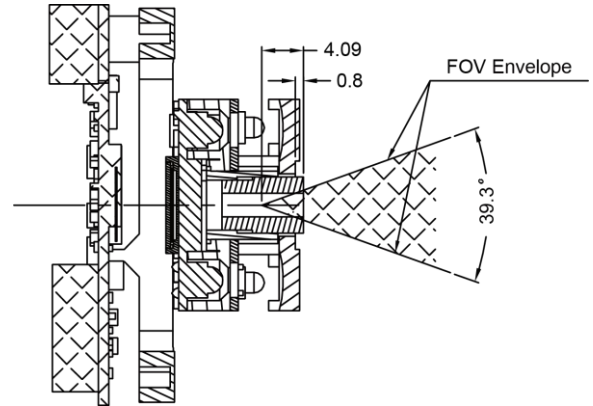
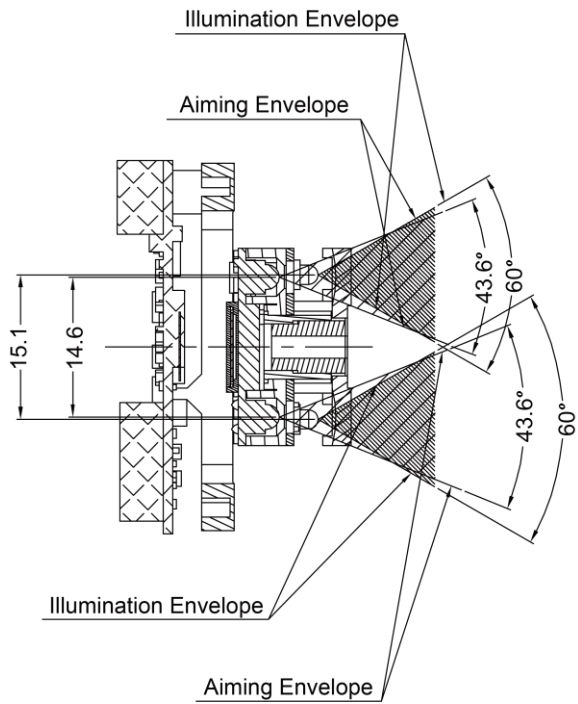

Vertical:

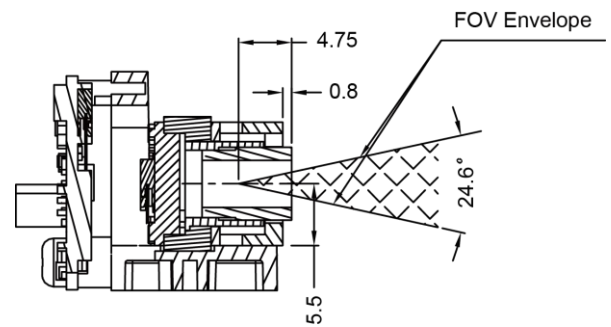
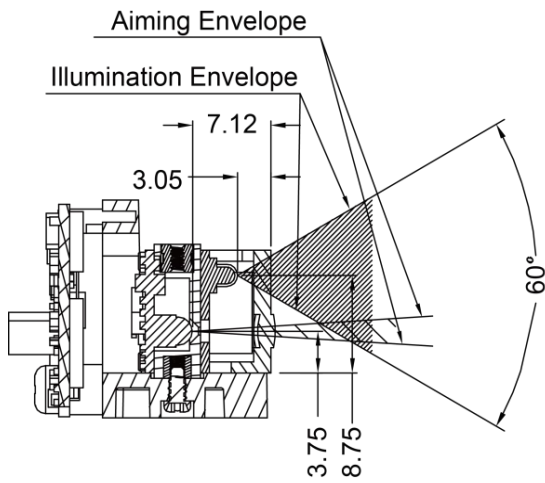
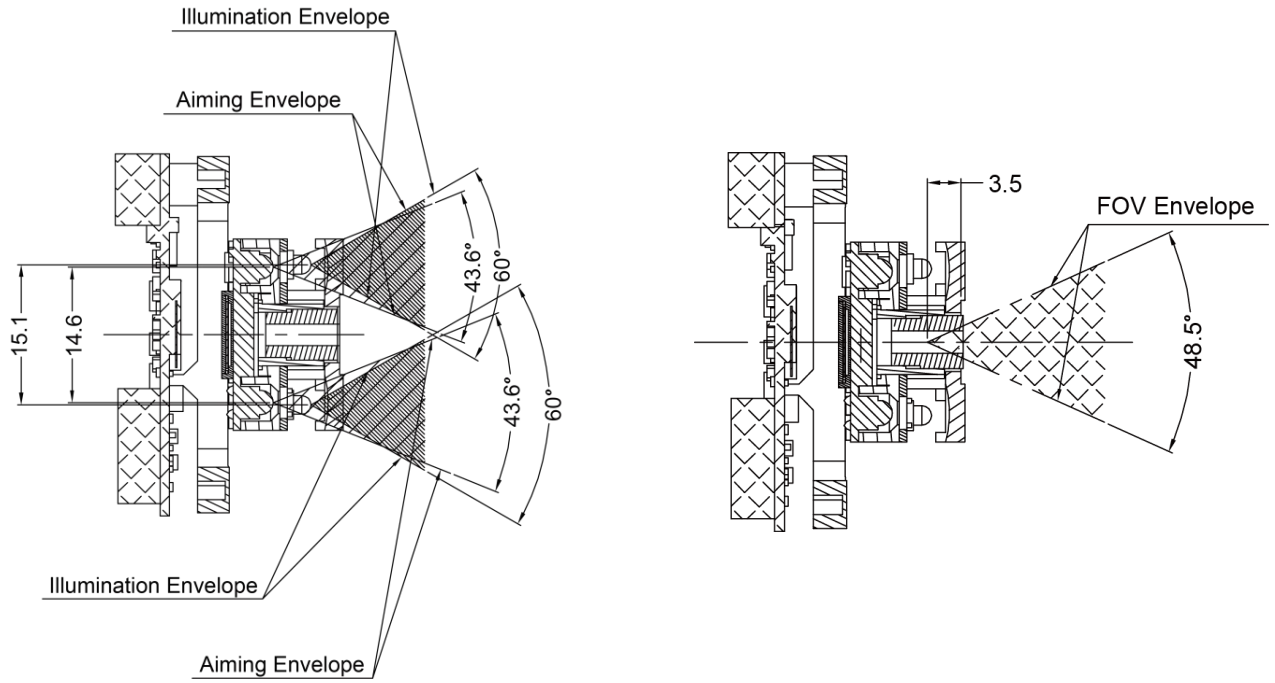

Figure 2-13

• HD version

Horizontal:



Vertical:

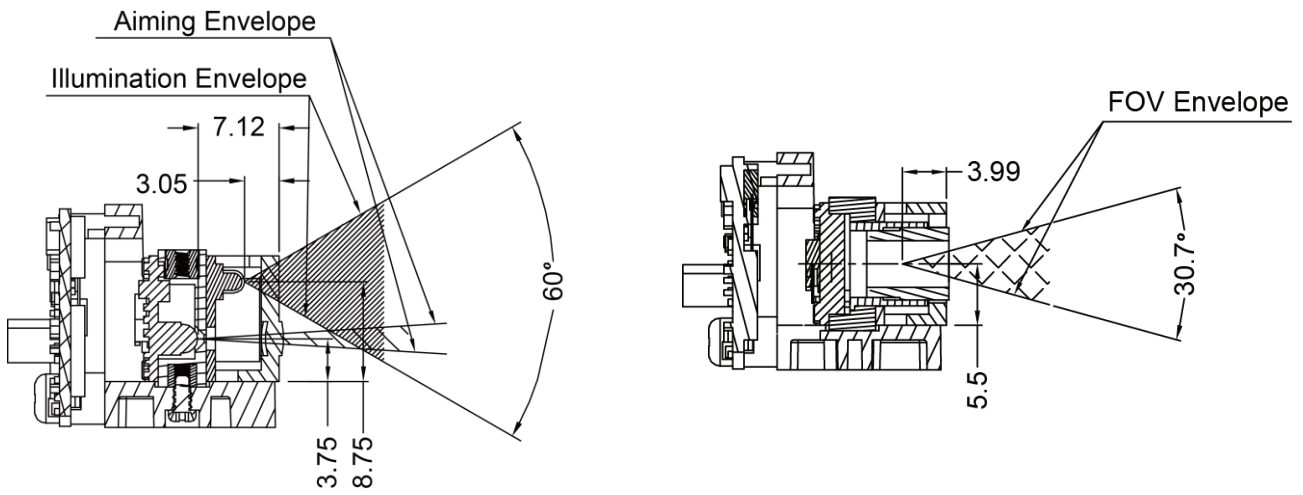

Figure 2-14

Skew, Roll and Pitch

Skew, roll and pitch of the engine are measured in the following way. For the engine's technical specifications, please visit the Newland website or contact your dealer.

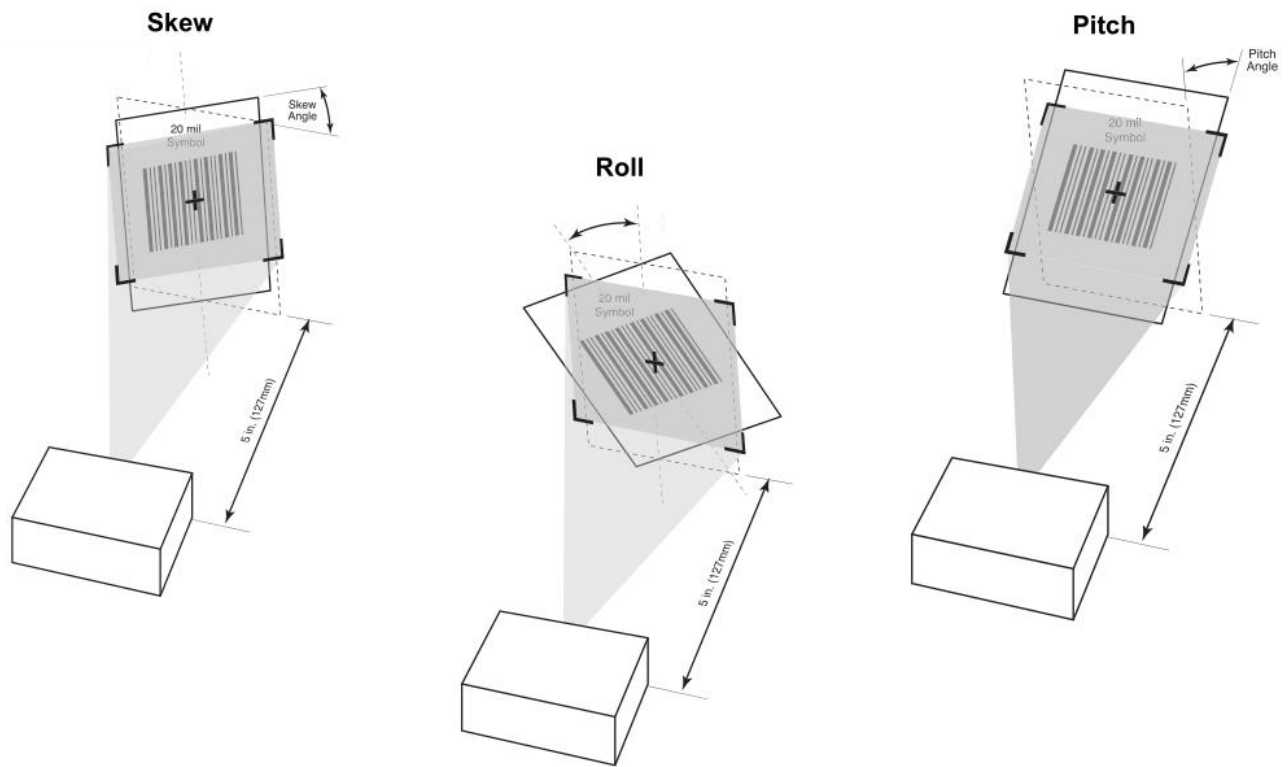

Figure 2-15

Ambient Light

The EM2037 shows better performance with ambient light. However, high-frequency pulsed light can result in performance degradation.

Eye Safety

The EM2037 has no lasers. It uses LEDs to produce illumination and aiming beams. The LEDs are bright, but testing has been done to demonstrate that the engine is safe for its intended application under normal usage conditions. However, the user should avoid looking into the beam.

Chapter 3 Electrical Specifications

Power Supply

Do not power up the EM2037 until it is properly connected. Be sure the power is cut off before connecting a cable to or disconnecting a cable from the host interface connector. Hot-plugging could damage the engine.

Unstable power supply or sharp voltage drops or unreasonably short interval between power-ons may lead to unstable performance of the engine. Do not resupply the power immediately after cutting it off.

Ripple Noise

To ensure the image quality, a power supply with low ripple noise is needed.

Acceptable ripple range (peak-to-peak) : $\leq 80\text{mV}$

DC Characteristics

Operating Voltage / Current

Table 3-1

T=23°C

Parameter	Description	Minimum	Typical	Maximum	Unit
Operating Voltage	VIN (12-pin FPC Connector)	3.0	3.3	5.5	V
	VIN (5-pin box Connector)	4.5	5.0	5.5	V
Current (@5.0V)	Operating Current	-	276.6	332.3	mA
	Standby Current	-	57.4	-	mA
Current (@3.3V)	Operating Current	-	400.8	498.6	mA
	Standby Current	-	80.5	-	mA

I/O Voltage

Table 3-2

VDD=3.3 V, VSS=0 V, T=23°C

Parameter	Minimum	Maximum	Unit
VIL	-0.3	0.8	V
VIH	2.0	3.6	V
VOL	VSS	0.4	V
VOH	2.4	VDD	V

Timing Sequence

Power Up and Power Down Timing Sequence

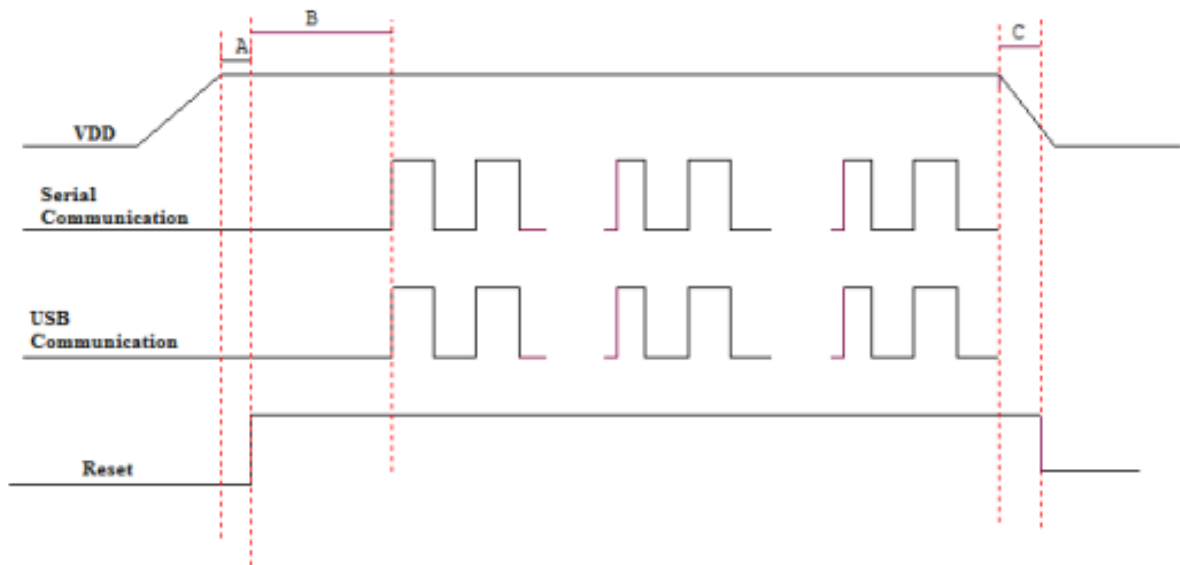

Figure 3-1

1. In the diagram above, it takes **A+B** (about 970ms) for the engine to power up: **A** is reset time (about 298ms), **B** is time needed to start the engine (including bootloader execution, kernel boot and decoding chip initialization). The engine is ready to receive commands via its serial/USB port after the power-up sequence completes.
2. **C** is the time it takes to power down the engine (during power-down, all voltages in the engine ramp down, with all communication stopped and all signals at a low level). To ensure that all voltages are fully down and signals on the interfaces at a low level, the minimum interval between removing and resupplying the power must exceed 700ms.

Chapter 4 Interfaces

Interface Pinouts

The physical interface of the EM2037 consists of 12-pin FPC connector and 5-pin box connector:

- 12-pin FPC connector can be used as TTL-232 interface or USB interface.
- 5-pin box connector can only be used as standard USB interface.

The figure below illustrates the positions of 12-pin FPC connector and 5-pin box connector on the EM2037's decoder board, as well as the pin layout of the FPC connector.

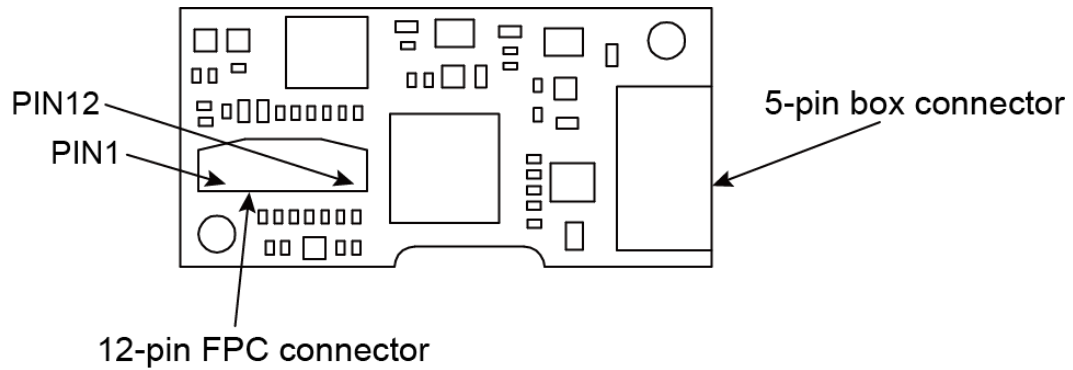

Figure 4-1

12-pin FPC Connector

The following table lists the pin functions of the 12-pin FPC connector.

Table 4-1

PIN#	Signal	I/O	Function	Remark
1	232INV	-	Reserved	Configurable with the software
2	VIN	-	Power supply input	
3	GND	-	Power-supply ground.	
4	RXD/USB_D-	I	TTL level 232 receive data/ USB D- differential data signal	See Note 1
5	TXD	O	TTL level 232 transmit data	See Note 1
6	nCTS/USB_D+	I	TTL level 232 clear to send /USB D+ differential data signal	See Note 1
7	nRTS	O	TTL level 232 request to send	See Note 1
8	PWRDWN	-	Reserved	Configurable with the software
9	nBeeper	O,od	Beeper output	See Note 2
10	nGoodRead	O,od	Good Read LED output	See Note 3
11	nWAKE	-	Reserved	Configurable with the software
12	nTRIG	I	Trigger signal input	See Note 4

※ I = Input; O = Output; od = Open Drain;

※ 1 Switching between TTL-232 and USB interfaces can be carried out by configuration of the 232INV signal (PIN 1) with the software. When the 232INV signal is set to high/ low level, the 12-pin FPC connector functions as TTL-232/ USB interface.

※ 2 This output signal can be used by an external beeper circuit to generate audible feedback to the user to indicate power-on and good read statuses.

Power On beep: The nBEEPER pin (PIN 9) produces a PWM output (duration: 400ms; frequency: 4184Hz, both parameters are **NOT** user-programmable) 970ms after power-on. The beep can be programmed On or Off. To learn how to program the parameter, please see the EM2037 V4 user guide.

Good Read beep: The nBEEPER pin (PIN 9) produces a PWM output (default duration: 80ms; default frequency: 2730Hz, both parameters are user-programmable) when a good read occurs. The beep can be programmed On or Off. To learn how to program these parameters, please see the EM2037 V4 user guide.

For the external beeper circuit design, please see the “Beeper Circuit” section in this chapter. If the nBEEPER pin is not used, leave it unconnected.

※ 3 This output signal can be used by an external LED to indicate good read status.

The nGoodRead pin (PIN 10) produces a low output (default duration: 20ms, user-programmable) when a good read occurs. The Good Read LED can be programmed On or Off. To learn how to program these parameters, please see

the EM2037 V4 user guide.

For the external LED circuit design, please see the “Good Read LED Circuit” section in this chapter. If the nGoodRead pin is not used, leave it unconnected.

※ 4 This external trigger signal can be either level trigger or pulse trigger.

Level trigger: A trigger pull (i.e. driving the nTRIG pin low for over 10ms) activates a decode session. The decode session continues until a barcode is decoded or the trigger is released.

Pulse trigger: When the trigger is pulled and released (pulse width : 50ms), scanning is activated until a barcode is decoded or the decode session timeout expires.

For the external trigger circuit, please see the “Trigger Circuit” section in this chapter. If the nTRIG pin is not used, leave it unconnected.

5-pin Box Connector

The following table lists the pin functions of the 5-pin box connector.

Table 4-2

PIN#	Signal	I/O	Function
1	GND	-	Power-supply ground.
2	GND	-	Power-supply ground.
3	D+	I/O	USB D+ differential data signal
4	D-	I/O	USB D- differential data signal
5	VIN	-	Power supply input

Connector/Cable Specifications (Unit: mm)

The EM2037 is equipped with a 12-pin FPC connector and a 5-pin box connector.

12-pin FPC Connector

The 12-pin FPC connector on the EM2037 is a CviLux Corporation FFC/FPC connector (Model No.: CF20121V0R0-LF).

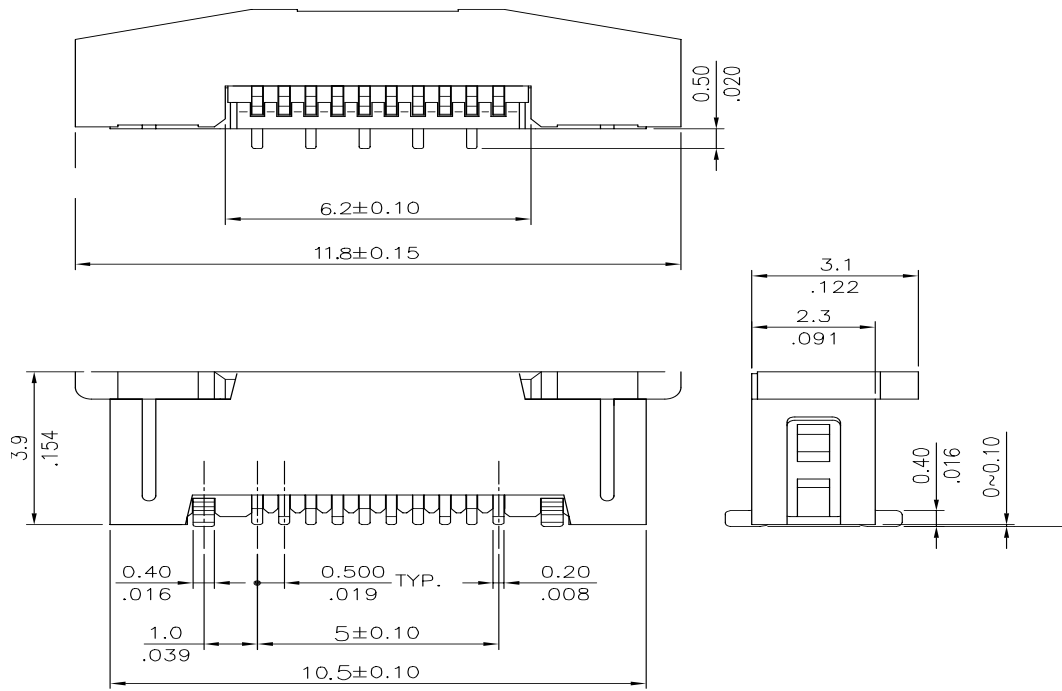

Figure 4-2

5-pin Box Connector

The 5-pin box connector on the EM2037 is supplied by Xiamen Lianye Electronics Co., Ltd., Model No.: PH-5AW.

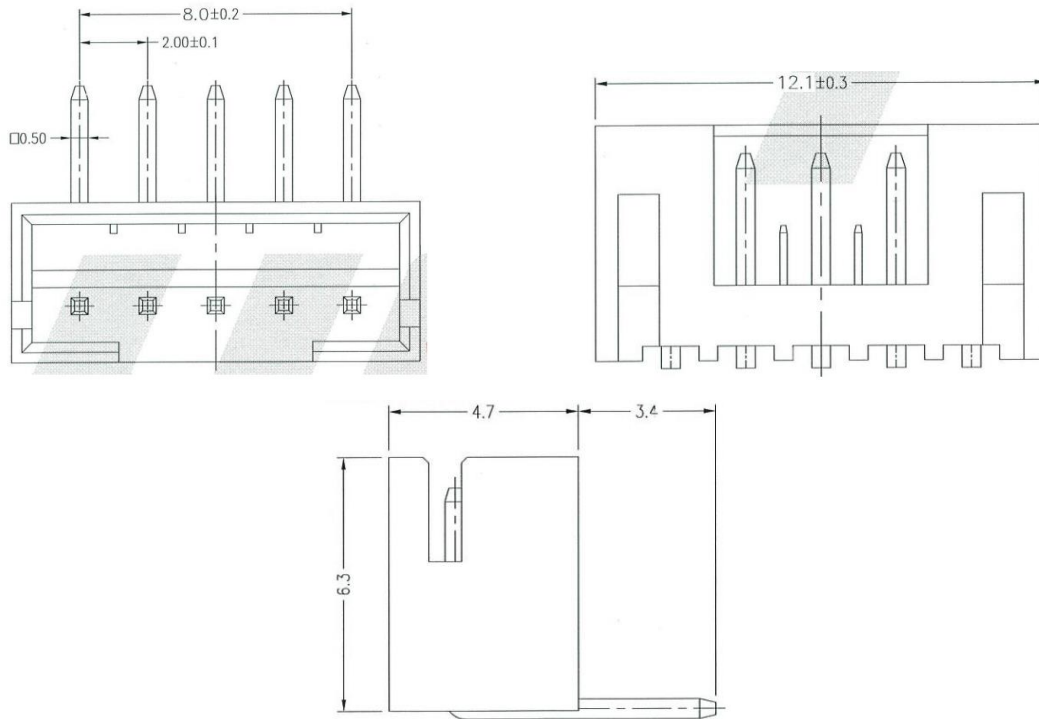
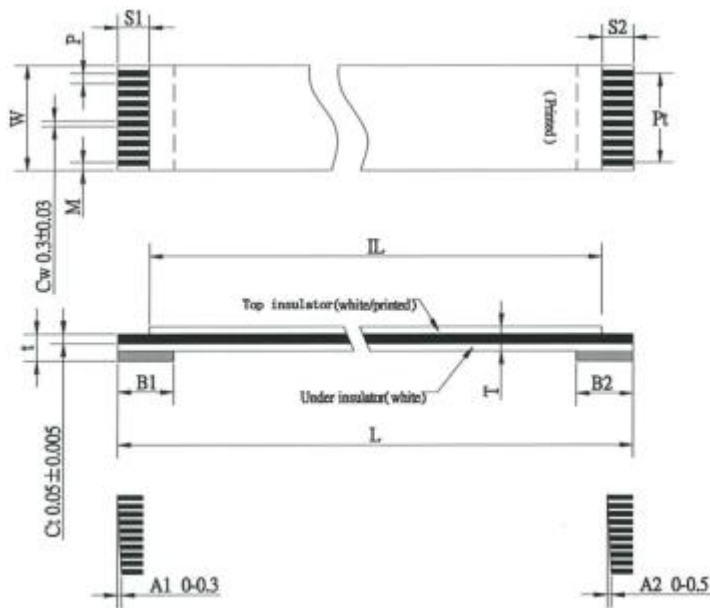

Figure 4-3

12-pin FFC Cable

A 12-pin cable can be used to connect the engine's 12-pin FPC connector to a host device.



Number of Conductors N ,	12P,
Pitch P ,	0.50 ± 0.05 ,
Total Pitch Pt ,	5.50 ± 0.07 ,
Total Length L ,	75.00 ± 2.00 ,
Film Length IL ,	69.00 ± 2.00 ,
Margin Width M ,	0.50 ± 0.07 ,
Total Width W ,	6.50 ± 0.07 ,
Strip Length $S1$,	3.00 ± 1.00 ,
Strip Length $S2$,	3.00 ± 1.00 ,
Stiffener $B1$,	4.00 ± 1.00 ,
Stiffener $B2$,	4.00 ± 1.00 ,
Slanting $A1$,	≤ 0.30 ,
Slanting $A2$,	≤ 0.05 ,
Terminal Thickness t ,	0.30 ± 0.05 ,
Thickness T ,	0.12 ± 0.05 ,

Figure 4-4

5-pin USB Female

A 5-pin USB female can be used to connect the engine's 5-pin box connector (male) to a host device.

Poles	2P	3P	4P	5P	6P	7P	8P	9P	10P	11P	12P	13P	14P	15P	16P
DIM.A	2.0	4.0	6.0	8.0	10.0	12.0	14.0	16.0	18.0	20.0	22.0	24.0	26.0	28.0	30.0
DIM.B	4.6	6.6	8.6	10.6	12.6	14.6	16.6	18.6	20.6	22.6	24.6	26.6	28.6	30.6	32.6
DIM.C	0.6	1.3	3.3	5.3	7.3	9.3	11.3	13.3	15.3	17.3	19.3	21.3	23.3	25.3	27.3

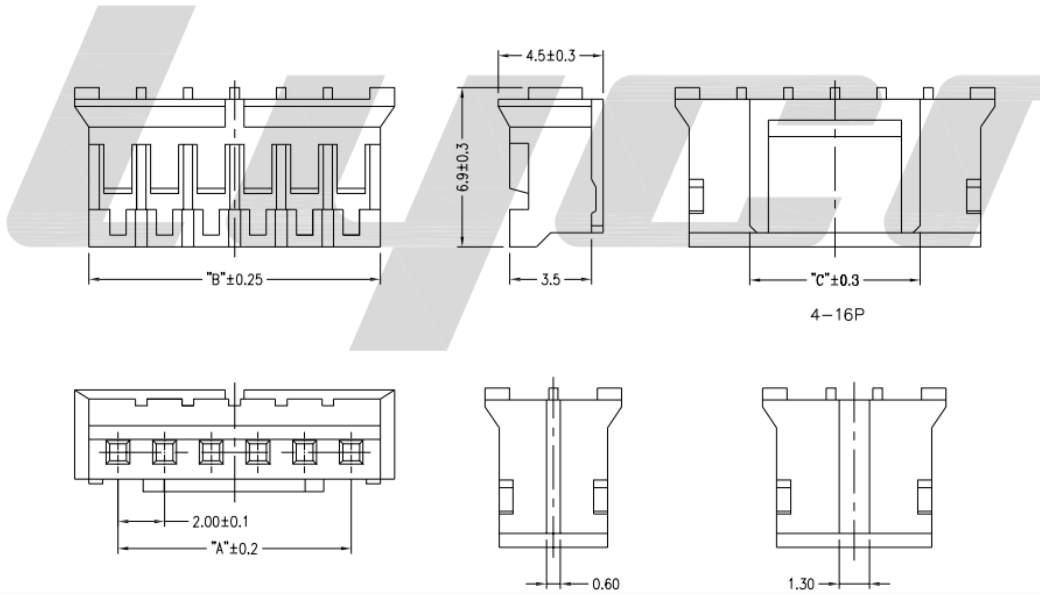

Figure 4-5

External Circuit Design

Good Read LED Circuit

The circuit below is used to drive an external LED for indicating good read. The left part shows internal LED driver circuit on the decoder board and the right part shows external circuit that users may utilize in actual application. The nGoodRead signal is from PIN 10 of the 12-pin FPC connector.

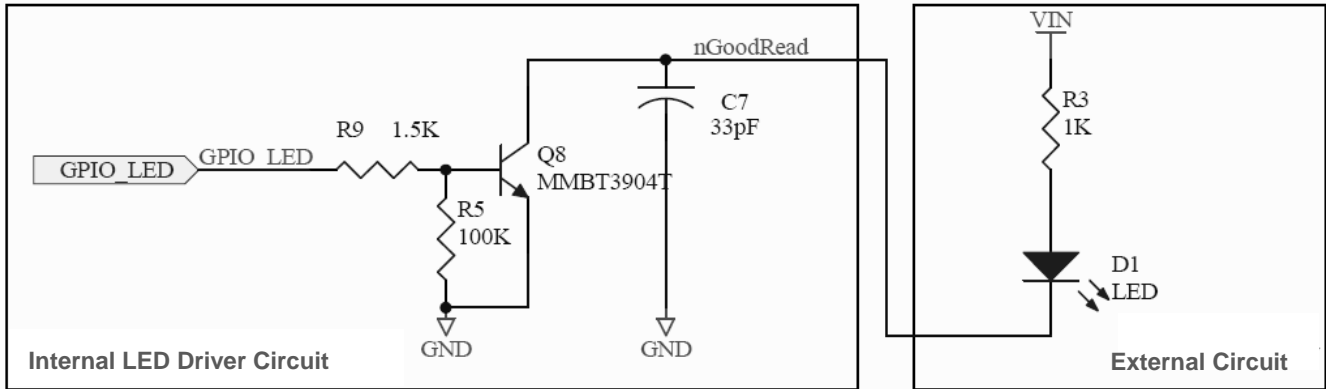

Figure 4-6

Beeper Circuit

The circuit below is used to drive an external beeper. The left part shows internal beeper driver circuit on the decoder board and the right part shows external circuit that users may utilize in actual application. The nBEEPER signal is from PIN 9 of the 12-pin FPC connector.

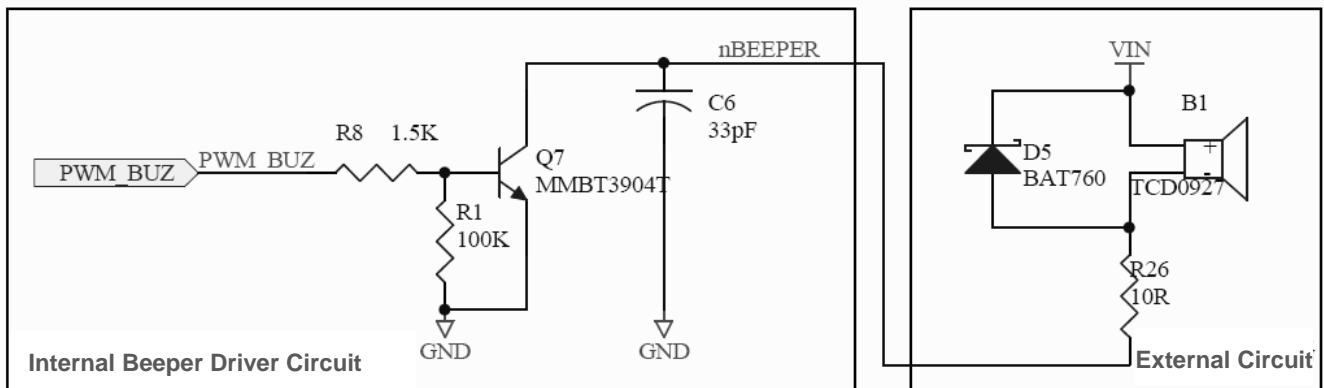

Figure 4-7

Trigger Circuit

The circuit below is used to provide the engine with a signal to trigger a scan and decode session. The right part shows internal trigger processing circuit on the decoder board and the left part shows external circuit that users may utilize in actual application. The nTRIG signal is from PIN 12 of the 12-pin FPC connector.

Users can adjust the external circuit and its function as per actual needs, on condition that the external circuit matches the internal circuit.

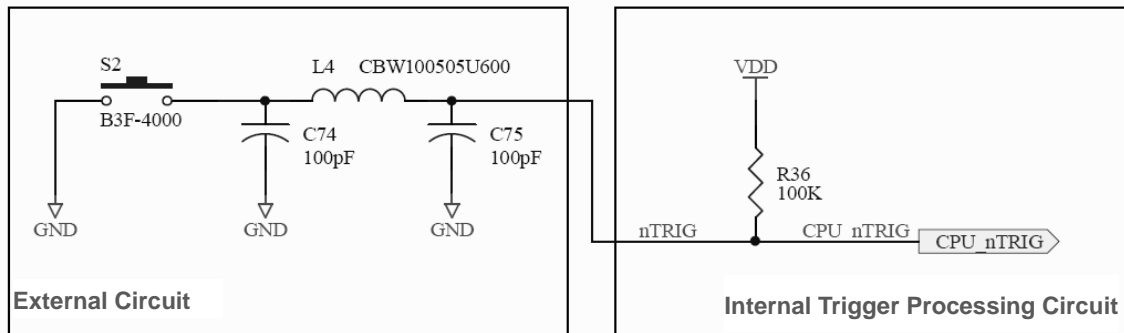

Figure 4-8

Chapter 5 Auxiliary Tools

The EM2037 provides the following two tools to assist users in engine performance evaluation, application development and engine configuration.

EVK

The EVK is provided to help users to test and evaluate the EM2037, which contains beeper & beeper driver circuit, LED & LED driver circuit, and trigger & reset buttons, TTL-232 to RS-232 converter & TTL-232 to USB converter, RS-232 & USB interfaces, etc. The EM2037 can be connected to the EVK via a 12-pin FFC cable type 1 (contacts on the same side). Either USB connection or RS-232 connection can be used when connecting the EVK to a host device.

EasySet

EasySet is a Windows-based configuration tool developed by Newland, which can be used to configure the EM2037.



Newland

SCANNING MADE SIMPLE

Newland EMEA HQ

+31 (0) 345 87 00 33
info@newland-id.com
newland-id.com

D-A-C-H

+49 (6) 182 82916-16
info@newland-id.de

Benelux

+31 (0) 345 87 00 33
benelux@newland-id.com

Italy

+39 (0) 342 0562227
italy@newland-id.com

United Kingdom

+44 (0) 1442 212020
sales@newland-id.co.uk

South Africa

Gauteng: +27 (0) 11 553 8010
Cape Town: +27 (0) 21 9140819
info@newland-id.co.za

Turkey

+90 (0) 544 538 40 49
turkey@newland-id.com

France

+39 (0) 345 8804096
france@newland-id.com

Ibérica

+34 (0) 93 303 74 66
info@newland-id.es

Nordic & Baltic

+46 (0) 70 88 47 767
nordic@newland-id.com

Russia

+31 (0) 345 87 00 33
russia@newland-id.com

Middle East

+39 (0) 345 8804096
middleeast@newland-id.com

Iran

+90 (0) 544 538 40 49
iran@newland-id.com